

PRODUCT INFORMATION PACKET



Model No: 191207.00

Catalog No: 191207.00

SST Duck™ General Purpose Motor, 0.75 & 0.50 HP, 3 Ph, 60 & 50 Hz, 230/460 & 190/380 V,
1800 & 1500 RPM, 56C Frame, TENV

Operational at 208-230/460 V @60HZ



Regal and Leeson are trademarks of Regal Rexnord Corporation or one of its affiliated companies.
©2023 Regal Rexnord Corporation, All Rights Reserved. MC017097E





Nameplate Specifications

Phase	3	Output HP	0.75 & 0.50 Hp
Output KW	0.56 & 0.37 kW	Voltage	230/460 & 190/380 V
Speed	1740 & 1440 rpm	Service Factor	1.15 & 1.15
Frame	56C	Enclosure	Totally Enclosed Non Ventilated
Thermal Protection	No Protection	Efficiency	82.5 & 81.5 %
Ambient Temperature	40 °C	Frequency	60 & 50 Hz
Current	2.3/1.15 & 2/1 A	Power Factor	73
Duty	Continuous	Insulation Class	F
Design Code	B	KVA Code	L
Drive End Bearing Size	6205	Opp Drive End Bearing Size	6205
UL	Recognized	CSA	Y
CE	Y	IP Code	55
Number of Speeds	1		

Technical Specifications

Electrical Type	Squirrel Cage Induction Run	Starting Method	Across The Line
Poles	4	Rotation	Reversible
Resistance Main	17.8 Ohms	Mounting	Rigid Base
Motor Orientation	Horizontal	Drive End Bearing	Ball
Opp Drive End Bearing	Ball	Frame Material	Stainless Steel
Shaft Type	NEMA 56	Overall Length	9.78 in
Frame Length	6.00 in	Shaft Diameter	0.625 in
Shaft Extension	1.88 in	Assembly/Box Mounting	F1 ONLY
Connection Drawing	005010.01	Outline Drawing	16992900

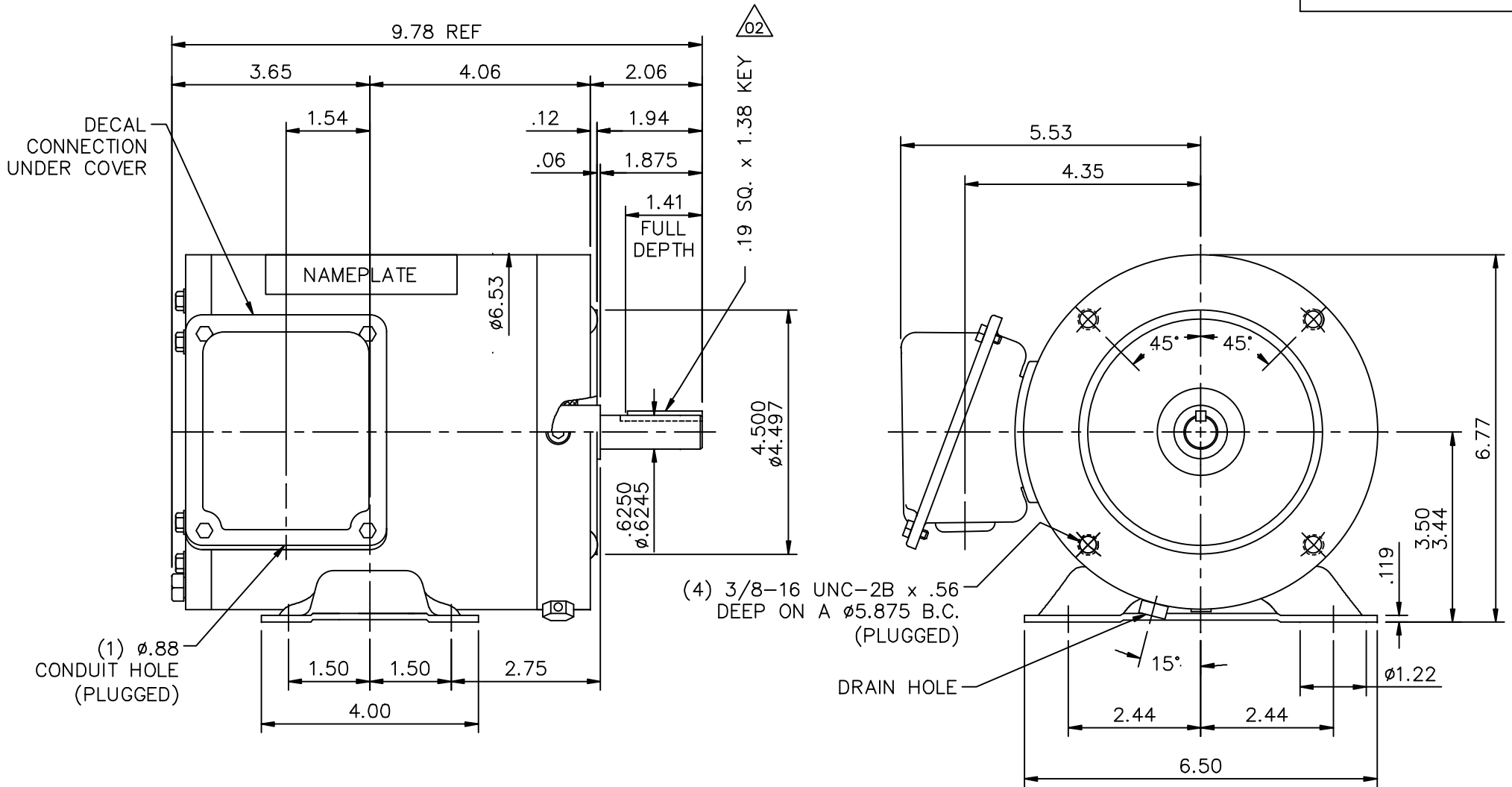

MAXIMUM FACE RUNOUT TO BE .004 T.I.R.
 MAXIMUM PILOT ECCENTRICITY .004 T.I.R.
 PERMISSABLE SHAFT RUNOUT .002 T.I.R.

GASKETS THROUGHOUT

				TOLERANCES UNLESS SPECIFIED			ELECTRIC MOTORS GEARMOTORS AND DRIVES	DRAWN MGM 04/10/03		
				DEC.	INCHES			CHK	RDW 04/10/03	
				.X	±.1			APPD		
				.XX	±.03	TITLE	OUTLINE - 56C FRAME TENV - RIGID "C"	SCALE	3=8	
02	UPDATED SHAFT EXT DIMS	RDW 4/26/04	SW	.XXX	±.005			REF		
01	CONDUIT HOLE WAS 1/2-14 NPT, DIM .157 WAS .12	SW 10/7/2003	RDW	.XXXX	±.0005	MAT'L.		FMF		
NO.	REVISION	BY & DATE	CHK	ANG	±1/2'	FINISH		PREV		
THIS DRAWING IN DESIGN AND DETAIL IS OUR PROPERTY AND MUST NOT BE USED EXCEPT IN CONNECTION WITH OUR WORK ALL RIGHTS OF DESIGN AND INVENTION ARE RESERVED THIS IS AN ELECTRONICALLY GENERATED DOCUMENT - DO NOT SCALE THIS PRINT				RFP		CAD FILE	16992900	SIZE	DRAWING NO.	REV.
				DIST				A	169929.00	01

005010-01

VIEW FROM OUTSIDE OF MOTOR AT SWITCH END.



VOLTAGE	L1	L2	L3	JOIN & INSULATE
HIGH	T1	T2	T3	(T4,T7) (T5,T8) (T6,T9)
LOW	T1,T7	T2,T8	T3,T9	T4,T5,T6

				TOLERANCES UNLESS SPECIFIED		REGAL ™ Regal Beloit America, Inc.		DRAWN RDW 04/12/02				
				DEC.	INCHES			CHK				
				.X	±.1			APPD				
				.XX	±.01			SCALE 1=1				
				.XXX	±.005	TITLE		REF FIG.2-51				
A	UPDATED TO REGAL LOGO			SAJ	06/26/15	AJY	.XXXX	±.0005	MAT'L. DECAL - 004014	FMF		
NO.	REVISION			BY & DATE	CHK	ANG	±1/2"	FINISH	PREV			
THIS DRAWING IN DESIGN AND DETAIL IS OUR PROPERTY AND MUST NOT BE USED EXCEPT IN CONNECTION WITH OUR WORK ALL RIGHTS OF DESIGN AND INVENTION ARE RESERVED THIS IS AN ELECTRONICALLY GENERATED DOCUMENT - DO NOT SCALE THIS PRINT				RFP	04/12/02		CAD FILE	00501001		SIZE	DRAWING NO.	REV.
				DIST	BRF-NLV			A	005010-01		A	



CERTIFICATION DATA SHEET

1051 CHEYENNE AVE.
GRAFTON, WI 53024
PH. 262-377-8810

CATALOG #: 191207.00

CONN. DIAGRAM: 005010.01

OUTLINE: 16992900

MOUNTING: F1 ONLY

WINDING #: QT6349 NR 3 A

TYPICAL MOTOR PERFORMANCE DATA

HP	kW	SYNC. RPM	F.L. RPM	FRAME	ENCLOSURE	KVA CODE	DESIGN
.75&.50	0.56&0.37	1800	1740&1440	56C	TENV	L	B

PH	Hz	VOLTS	AMPS	START TYPE	DUTY	INSL	S.F.	AMB°C
3	60/50	208-230/460&190/380	2.4-2.3/1.15&2/1	ACROSS THE LINE	CONTINUOUS	F5	1.15/1.15	40

FULL LOAD EFF:	82.5	3/4 LOAD EFF:	84	1/2 LOAD EFF:	80.9	GTD. EFF		ELEC. TYPE	
FULL LOAD PF:	73	3/4 LOAD PF:	63.1	1/2 LOAD PF:	50.6	-		SQ CAGE IND RUN	

F.L. TORQUE	LOCKED ROTOR AMPS	L.R. TORQUE	B.D. TORQUE	F.L. RISE°C
36 OZ-FT	18.6 / 9.3	116 OZ-FT 322 %	163 OZ-FT 453 %	79

SOUND PRESSURE @ 3 FT.	SOUND POWER	ROTOR WK^2	MAX. WK^2	SAFE STALL TIME	STARTS / HOUR	APPROX. MOTOR WGT
- dBA	- dBA	-1 LB-FT^2	- LB-FT^2	- SEC.	-	- LBS.

*** SUPPLEMENTAL INFORMATION ***

DE BRACKET TYPE	ODE BRACKET TYPE	MOUNT TYPE	ORIENTATION	SEVERE DUTY	HAZARDOUS LOCATION	DRIP COVER	SCREENS	PAINT
C-FACE	STANDARD	RIGID	HORIZONTAL	FALSE	NONE	FALSE	NONE	BLUE (ENAMEL)

BEARINGS		GREASE	SHAFT TYPE	SPECIAL DE	SPECIAL ODE	SHAFT MATERIAL	FRAME MATERIAL
DE	ODE						
BALL	BALL	POLYREX EM	STANDARD 56	NONE	NONE	1045 HOT ROLLED (C-204)	ROLLED STEEL
6205	6205						

THERMO-PROTECTORS				THERMISTORS	CONTROL	SPACE HEATERS
THERMOSTATS	PROTECTORS	WDG RTDs	BRG RTDs			
NONE	NOT	NONE	NONE	NONE	FALSE	NONE VOLTS

*
N
O
T
E
S

INVERTER TORQUE: NONE
INV. HP SPEED RANGE: NONE
ENCODER: NONE
NONE NONE
NONE NONE PPR
BRAKE: NONE NONE
NONE P/N NONE
NONE NONE
NONE FT-LB NONE V NONE Hz

Data Sheet

Date: 1/22/2018

191207.00



Data @ 460 V

Motor Load Data

Load	0%	25%	50%	75%	100%	115%	125%	LR
Current (Amps)	0.70	0.77	0.87	1.00	1.15	1.24	1.32	9.3
Torque (ft-lb)	0.00	144	288	432	576	10,384	721	1,857
RPM	1800	1787	1776	1763	1752	1,746	1738	0
Efficiency (%)		69.7	80.9	84.0	82.6	83.8	84.9	
P.F. (%)	14.0	33.4	50.6	63.1	74.0	75.9	77.8	0.0

Motor Speed Data

	LR	Pull-Up	BD	Rated	Idle
Speed (RPM)	0	900	1656	1752	1800
Current (Amps)	9.3	8.6	5.6	1.15	0.70
Torque (ft-lb)	1,857	1,809	2,610	576	0.00

Information Block				
HP	0.8			
Sync. RPM	1800			
Frame	0			
Enclosure	TENV			
Construction	NA			
Voltage	208-230/460#190/380 V			
Frequency	60 Hz			
Design	B			
LR Code letter	L			
Service Factor	1.15			
Temp Rise @ FL	80 °C			
Duty	CONT			
Ambient	40 °C			
Elevation	1,000 feet			
Rotor/Shaft wk ²	-1.00 Lb-Ft ²			
Ref Wdg	QT6349 NR			
Sound Pressure @ 1M	999 dBA			
VFD Rating	NONE			
Outline Dwg	16992900			
Conn. Dwg	005010.01			
Additional Specifications:				
0				
0				
EQUIV CKT (OHMS / PHASE)				
R1	R2	X1	X2	Xm
0.0000	0.0000	0.0000	0.0000	0.0000

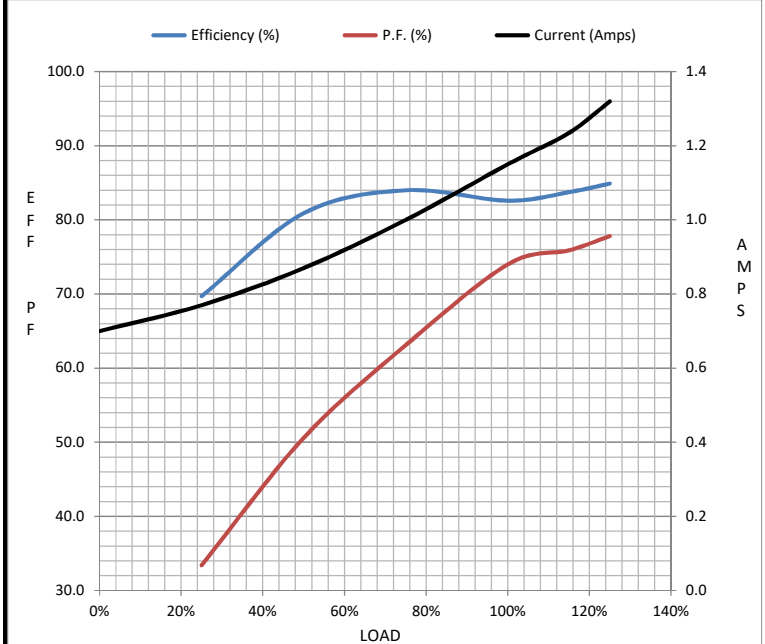

Speed - Torque Curve

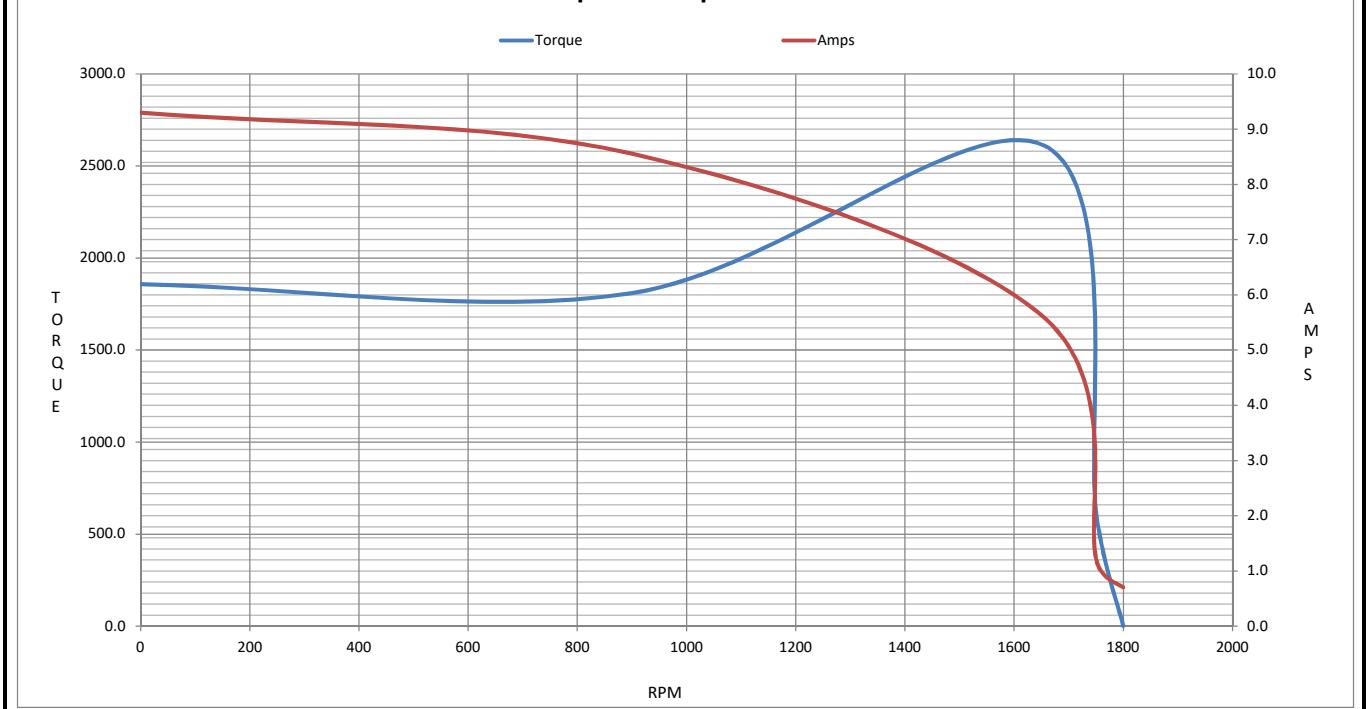

EC Declaration of Conformity

The undersigned representing
the manufacturer:

Regal Beloit America
100 East Randolph St.
Wausau, WI 54401

and the authorized representative
established within the Community:

Marathon Electric UK
6F Thistleton Road Ind. Estate
Market Overton
Oakham, Rutland LE15 7PP UK

are committed to providing customers with products that comply with applicable regulations and international protocols to which they are subject, including the requirements of the European Parliament Directive on the Harmonization of the laws relating to electrical equipment designed for use within certain voltage limits (2014/35/EU).

Regal Beloit America declares that the following product(s), to which this declaration relates, are in conformity with the relevant sections of the EC standards listed below.

This statement supersedes any statements previously issued pertaining to the product(s) listed below and is subject to change without notice.

Model No : 191207.00

(Model No. may contain prefix and/or suffix characters)

Catalog No : 191207.00

Rework No : N/A

Directives :

Low Voltage Directive 2014/35/EU

Harmonized Standards Used :

EN 60034-1: 2010 (IEC 60034-1: 2010)

EN 60034-5: 2001/A1:2007 (IEC 60034-5: 2000/A1:2006)

Authorized Representative:

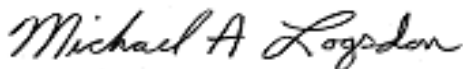

Michael A. Logsdon
Vice President, Technology

Authorized Representative in the Community:



Julian Clark
Marketing Engineer

Created on 09/01/2022

CE 22